

WS 6215-LED-Z10 The LED Wedge™

WEDGE™ LED INSTALLATION INSTRUCTIONS

READ ALL INSTRUCTIONS CAREFULLY

CAUTION: **DISCONNECT POWER SUPPLY BEFORE INSTALLATION**
CAUTION: **RISK OF FIRE:**
Most dwellings built before 1985 have supply wire rated 60°C.
Consult a qualified electrician before installing.

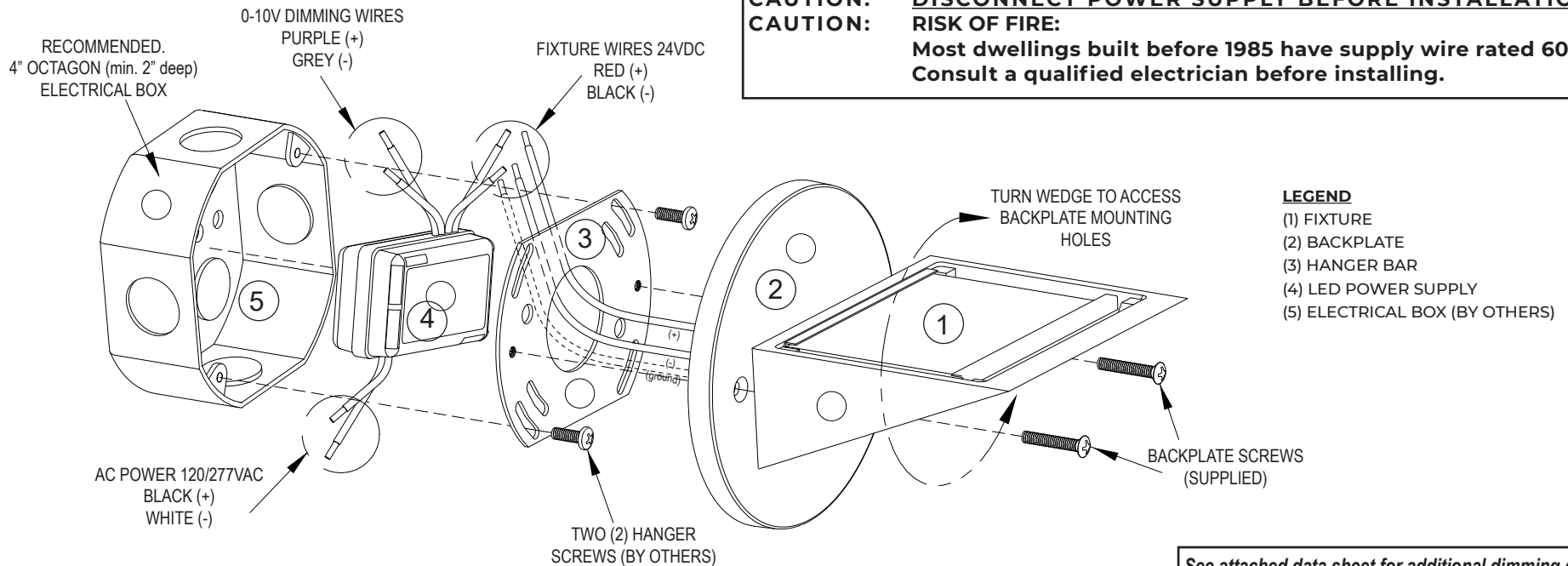

LEGEND
(1) FIXTURE
(2) BACKPLATE
(3) HANGER BAR
(4) LED POWER SUPPLY
(5) ELECTRICAL BOX (BY OTHERS)

See attached data sheet for additional dimming details

FIXTURE INSTALLATION

THIS PRODUCT MUST BE INSTALLED IN ACCORDANCE WITH THE APPLICABLE INSTALLATION CODE BY A PERSON FAMILIAR WITH THE CONSTRUCTION AND OPERATION OF THIS PRODUCT AND THE HAZARDS INVOLVED.

STEP 1: TURN OFF THE POWER SUPPLY TO THE ELECTRICAL BOX

Recommended 4" octagonal electrical box, 2" min deep (#4)

STEP 2: WIRE LED POWER SUPPLY

- Wire main AC power (120/277VAC) to LED Power Supply (#4). White (-), Black (+), Green (Ground)

FOR NON DIMMING

- Cap the Purple and Gray wires. These wires may be shortened.

FOR DIMMING

This fixture is compatible with 0-10V DC dimmer switches ONLY.

The dimmer switch wires must be in place or installed and routed into the electrical box.

- Connect the Purple (+) and Gray (-) wires to the dimming switch's Purple (+) and Gray (-) wires.

- Insert the LED Power Supply (#4) into the electrical box (#5)

STEP 3: INSTALL THE HANGER BAR

- Pull the Red (+) and Black (-) wires from the LED Power Supply (#4) thru the hanger bar (#3) center hole.

- Attach the hanger bar (#3) to the Electrical Box (#5) with the two (2) screws that come with the electrical box (supplied by others).

STEP 4: WIRE THE LED FIXTURE

- Connect the Red (+) and Black (-) wires from the LED power supply (#4) to the Red (+) and Black (-) fixture wires.

- "Tuck" the wires thru the hanger bar (#3) center hole into the electrical box.

STEP 5: INSTALL THE FIXTURE

The Wedge Fixture can be turned to access the mounting holes.

- Grasp the backplate (#2), then turn the Fixture (#1)

- Install with the supplied screws, then turn the Fixture (#1) back to the horizontal position.

STEP 6: TURN THE POWER ON

PO BOX 2079, OCEAN NJ 07712

(732)493-2666 SALES@BELFER.COM

COPYRIGHT© BELFER LIGHTING. NO RIGHTS ARE GRANTED FOR REPRODUCTION, DISCLOSURE OR USE.

PROUDLY MADE IN THE USA

P-1719-02 030122 ESB