

# INSTALLATION INSTRUCTIONS FOR MQ2502FX

## PLEASE READ ALL INSTRUCTIONS CAREFULLY

*NOTE: COVE SURFACE MUST BE A MINIMUM OF 2" AROUND THE LAMPS.  
 \_\_\_\_\_ (SEE BELOW)*

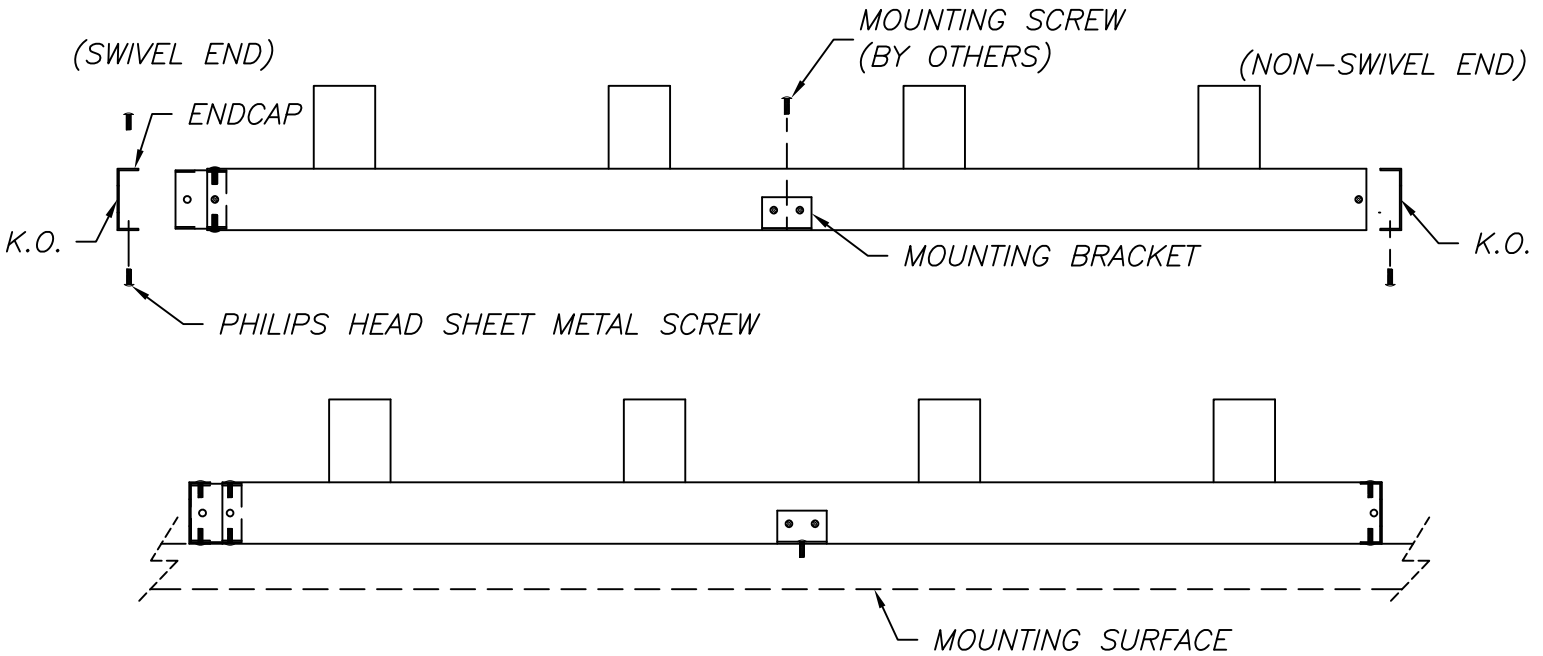
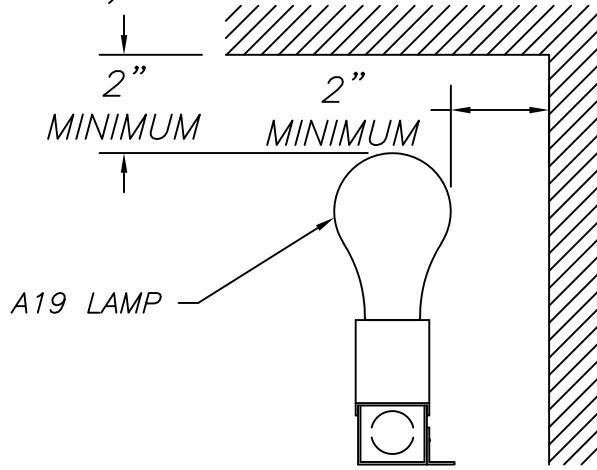

NOTE: WIRING CAN BEGIN AT EITHER END OF FIXTURE.

**WIRING INSTRUCTIONS:**

1. **IMPORTANT: VERIFY ALL POWER HAS BEEN SHUT OFF.....**
2. UNSCREW PHILIPS HEAD SHEET METAL SCREWS AND REMOVE END CAP.
3. KNOCK OUT APPROPRIATE K.O.
4. CONNECT FITTINGS TO END CAP.
5. WIRE IN ACCORDANCE WITH THE N.E.C. CODE AND ANY APPLICABLE LOCAL CODES.
6. REPLACE END CAP AND TIGHTEN WITH PHILIPS HEAD SHEET METAL SCREWS.
7. REMOVE OPPOSITE END CAP, INSULATE AND STORE EXTRA WIRES.
8. REPLACE END CAP AND TIGHTEN WITH PHILIPS HEAD SHEET METAL SCREWS.
9. MOUNT FIXTURE TO SURFACE, USING ATTACHED MOUNTING BRACKETS, WITH MOUNTING SCREWS. (BY OTHERS)

\*SEE OPPOSITE SIDE (Page 2 Of 2) FOR INSTRUCTIONS ON JOINING TWO FIXTURES.\*

ALL DIMENSIONS ARE IN INCHES  
 UNLESS OTHERWISE SPECIFIED

# BELFER LIGHTING

NEW JERSEY, USA - 732-493-2666  
 COPYRIGHT © BELFER LIGHTING  
 NO RIGHTS ARE GRANTED FOR  
 REPRODUCTION, DISCLOSURE, OR USE.

TITLE <i>MQ2502FX INSTALLATION INSTRUCTIONS</i>						
DATE	9/14/17	SCALE	NTS	DRAWN	RPM	APPROVED
SHEET	1 OF 2	DWG. NO.		MQ2502FX		REV.
						0

FRACTIONAL	±1/32
.XX	±0.01
.XXX	±0.005
ANGULAR	±1/2°

**INSTALLATION INSTRUCTIONS FOR MQ2502FX**  
**PLEASE READ ALL INSTRUCTIONS CAREFULLY**

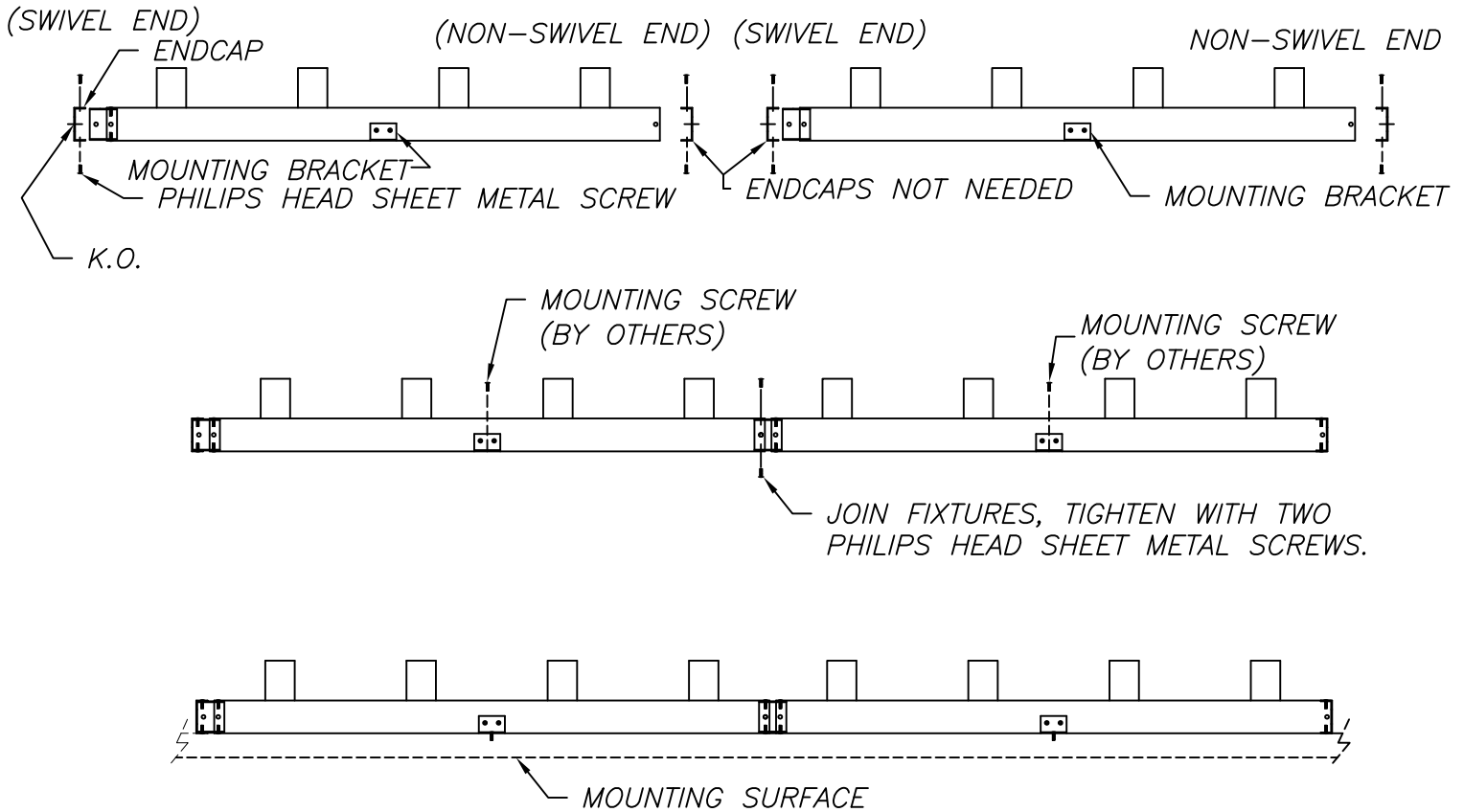

NOTE: WIRING CAN BEGIN AT EITHER END OF FIXTURE.

**WIRING INSTRUCTIONS FOR JOINING MORE THAN ONE FIXTURE:**

- 1. IMPORTANT VERIFY ALL POWER HAS BEEN SHUT OFF.....**
2. UNSCREW PHILIPS HEAD SHEET METAL SCREWS AND REMOVE SWIVEL END AND NON-SWIVEL END.  
(THE TWO END CAPS IN BETWEEN EACH JOINING FIXTURES WILL NOT BE NEEDED)
3. KNOCK OUT APPROPRIATE K.O.
4. CONNECT FITTINGS TO END CAP.
5. WIRE IN ACCORDANCE WITH THE N.E.C. CODE AND ANY APPLICABLE LOCAL CODES.
6. JOIN FIXTURES TOGETHER USING SWIVEL JOINT AND THE PHILIPS HEAD SHEET METAL SCREWS AND TIGHTEN.
7. AT THE OPPOSITE END CAP, INSULATE AND STORE EXTRA WIRES.
8. REPLACE END CAP AND TIGHTEN WITH PHILIPS HEAD SHEET METAL SCREWS.
9. MOUNT FIXTURE TO SURFACE, USING ATTACHED MOUNTING BRACKETS, WITH MOUNTING SCREWS. (BY OTHERS)

*\*SEE OPPOSITE SIDE (Page 1 Of 2) FOR INSTRUCTIONS ON SINGLE FIXTURES.\**

ALL DIMENSIONS ARE IN INCHES  
UNLESS OTHERWISE SPECIFIED

**BELFER LIGHTING**

NEW JERSEY, USA - 732-493-2666  
 COPYRIGHT © BELFER LIGHTING  
 NO RIGHTS ARE GRANTED FOR  
 REPRODUCTION, DISCLOSURE, OR USE.

TITLE MQ2502FX INSTALLATION INSTRUCTIONS				
DATE	9/14/17	SCALE	NTS	DRAWN RPM
SHEET	2 OF 2	DWG. NO.	MQ2502FX	REV. 0
APPROVED				

FRACTIONAL	±1/32
.XX	±0.01
.XXX	±0.005
ANGULAR	±1/2°