

INSTALL INSTRUCTIONS FOR MQ2502, MQ2503, MQ2504, MQ2505

PLEASE READ ALL INSTRUCTIONS CAREFULLY

REMOVE EITHER
STYLE CAP FROM BODY
BY PRYING CAP OFF

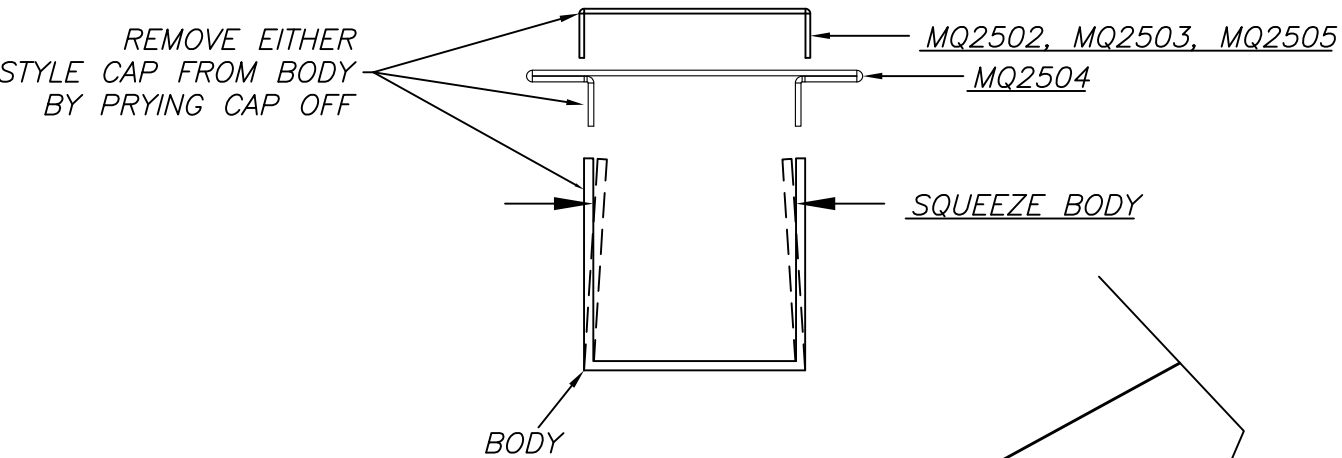

SQUEEZE BODY
BODY
(FASTEN TO MOUNTING SURFACE BY
DRILLING AS NEEDED, SEE #9)

REMOVE CAP FROM
BODY BY PRYING OFF

REMOVE CAP FROM
BODY BY REMOVING
SCREWS(3)

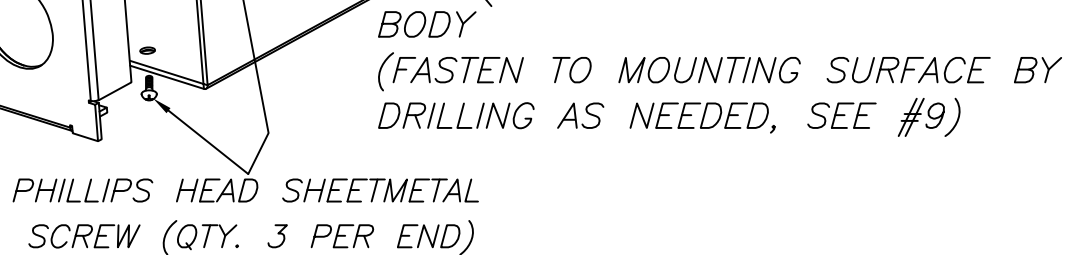

WIRING INSTRUCTIONS:

1. **IMPORTANT: VERIFY ALL POWER HAS BEEN SHUT OFF.....**
2. UNSCREW PHILIPS HEAD SHEET METAL SCREWS AND REMOVE END CAP.
3. KNOCK OUT APPROPRIATE K.O.
4. CONNECT FITTINGS TO END CAP.
5. WIRE IN ACCORDANCE WITH THE N.E.C. CODE AND ANY APPLICABLE LOCAL CODES.
6. REPLACE END CAP AND TIGHTEN WITH PHILIPS HEAD SHEET METAL SCREWS.
7. REMOVE OPPOSITE END CAP, INSULATE AND STORE EXTRA WIRES.
8. REPLACE END CAP AND TIGHTEN WITH PHILIPS HEAD SHEET METAL SCREWS.
9. FASTEN BODY TO MOUNTING SURFACE USING FASTENERS APPROPRIATE TO SITE CONDITIONS, BY DRILLING AS NEEDED.
10. ALIGN BODY AND CAP AND APPLY PRESSURE AND SNAP TOGETHER.

ALL DIMENSIONS ARE IN INCHES
UNLESS OTHERWISE SPECIFIED

BELFER LIGHTING

NEW JERSEY, USA - 732-493-2666
COPYRIGHT © BELFER LIGHTING
NO RIGHTS ARE GRANTED FOR
REPRODUCTION, DISCLOSURE, OR USE.

TITLE MQ2502, MQ2503, MQ2504, MQ2505
INSTALLATION INSTRUCTIONS

DATE	9/18/17	SCALE	NTS	DRAWN	RPM	APPROVED
SHEET	1 OF 1	DWG. NO.	MQ2502/03/04/05		REV.	0

FRACTIONAL	±1/32
.XX	±0.01
.XXX	±0.005
ANGULAR	±1/2°